

olimpic k 230

compact automatic **edge bander**

Easy-to-use and with all inclusive equipment: olimpik k 230, due to its advanced technological solutions designed to ensure optimal panel finishing, is the perfect edge bander for companies beginning and requiring professional edge banding



OLIMPIC		K 230
Panel thickness	mm	8 - 50
Edge thickness	mm	0,4 - 3
Feed speed	m/min	9
Compressed air	bar	6

- cutting
- edge banding**
- boring-routing
- calibrating-sanding
- assembling

olimpic k 230

technological advantages



toptech

PANEL MOVEMENT SYSTEM: DESIGNED FOR A PERFECT FINISH

The **very best finishing of the panel edge** is also guaranteed by the panel conveying track (Scm patent), which prevents the panel having the feed affected by the typical pulse generated by the pinion of a traditional feed track.



K-2 END CUTTING UNIT: CUT AND "RADIUS" IN A SINGLE OPERATION

Automatic and error free cutting of thick edges due to the particular system with two blades that allows the straight cutting of solid wood edges and the chamfering of the thin edges.



ORION ONE PLUS CONTROL SYSTEM: SIMPLE AND INTUITIVE MACHINE USE

Error-free machining is ensured by the control with its buttons and customised graphics and 4" display allows an easy selection of the main machine functions.

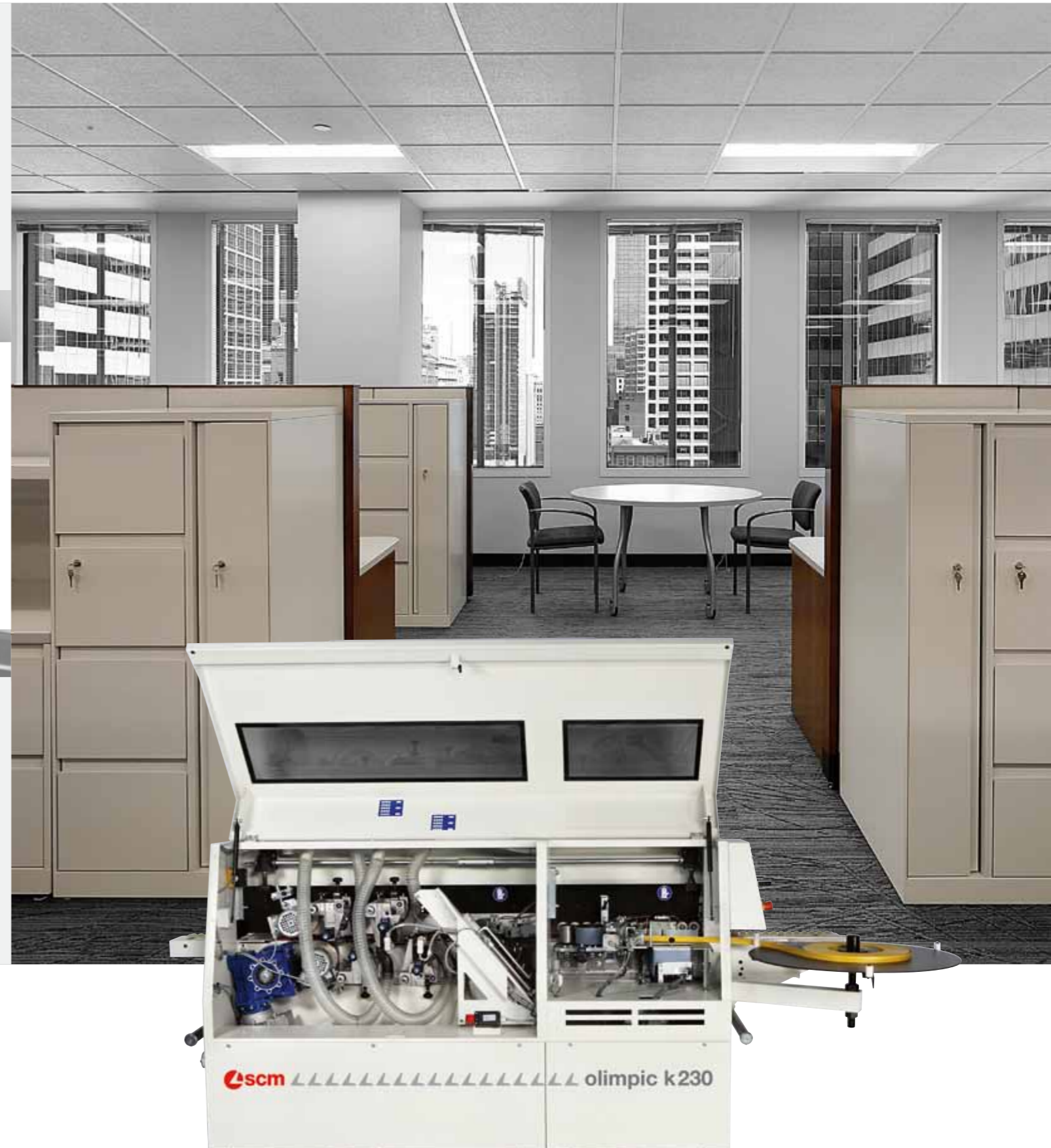

olimpic k 230

operating groups

ORION ONE PLUS CONTROL SYSTEM: SIMPLE AND INTUITIVE MACHINE USE

Error-free machining is ensured by the control with its buttons and customised graphics and 4" display allows an easy selection of the main machine functions.

- visualisation of the main production data
- diagnostics to obtain a quick solution to any malfunctions

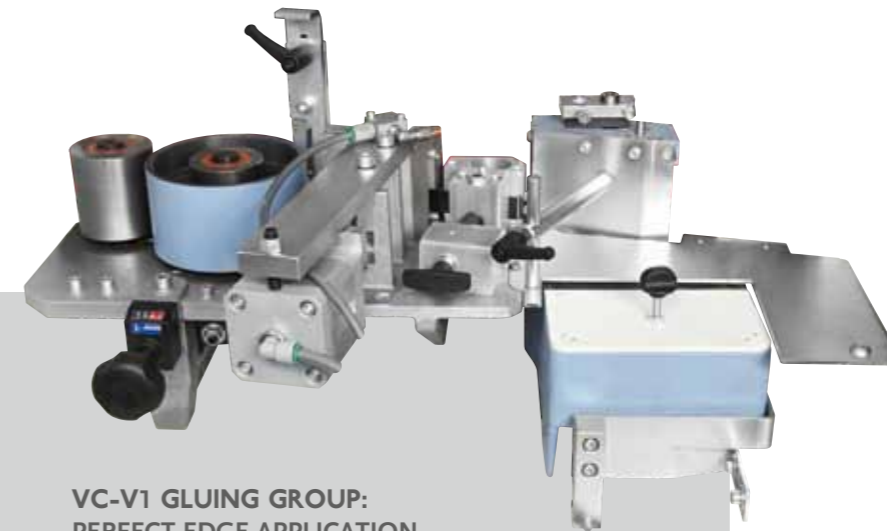

VC-V1 GLUING GROUP: PERFECT EDGE APPLICATION

Optimal edge gluing is guaranteed by a particular glue spreading roller providing a **uniform and optimised glue application** and the absence of excess glue on all types of material. Automatic lowering of the glue temperature after a temporary halt in using the machine.

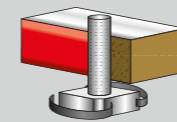

KIT FOR MACHINING OF EDGES IN STRIPS

Automatic loading of edges in strips with thickness 0,4-3 mm (opt.)

K-2 END CUTTING GROUP: CUT AND "RADIUS" IN A SINGLE OPERATION

Automatic and error free cutting of thick edges due to the particular system with two blades that allows the straight cutting of solid wood edges and the chamfering of thin edges

- group with two motors (optional group supplied to replace the K-1 end cutting group)



olimpic k 230

operating groups

“COMBI” TOOLS

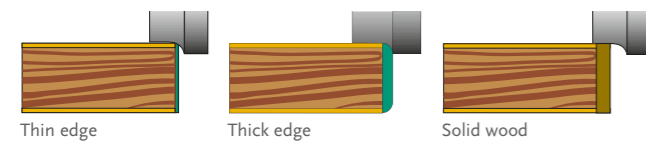

R-K TRIMMING GROUP:

HIGH WORKING VERSATILITY

Rapid machining changeover between thin, thick and solid wood edges due to the 3 manually selectable working positions and the “Combi” tool supplied as a standard feature.

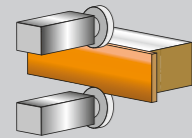

RAS-V EDGE SCRAPING GROUP:

FOR PERFECT PVC/ABS RADIUS EDGES

High finishing quality of PVC/ABS edges due to the complete **elimination of any of the marks** left from the trimming group tools (opt.).
- the group is supplied, as a standard feature, with an extraction hood complete with a suitable container and filter for long chips.

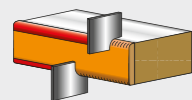

RC-V GLUE SCRAPING GROUP:

A PERFECT EDGE JOINT LINE

It eliminates any excess glue on the panel/edge joint.

It allows the removal of any excessive plastic edges (0,1 mm for edges up to 1 mm) (opt.).
- the group is supplied, as a standard feature, with extraction hoods.

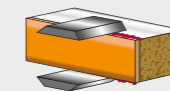

olimpic k 230

OLIMPIC K 230

dimensions

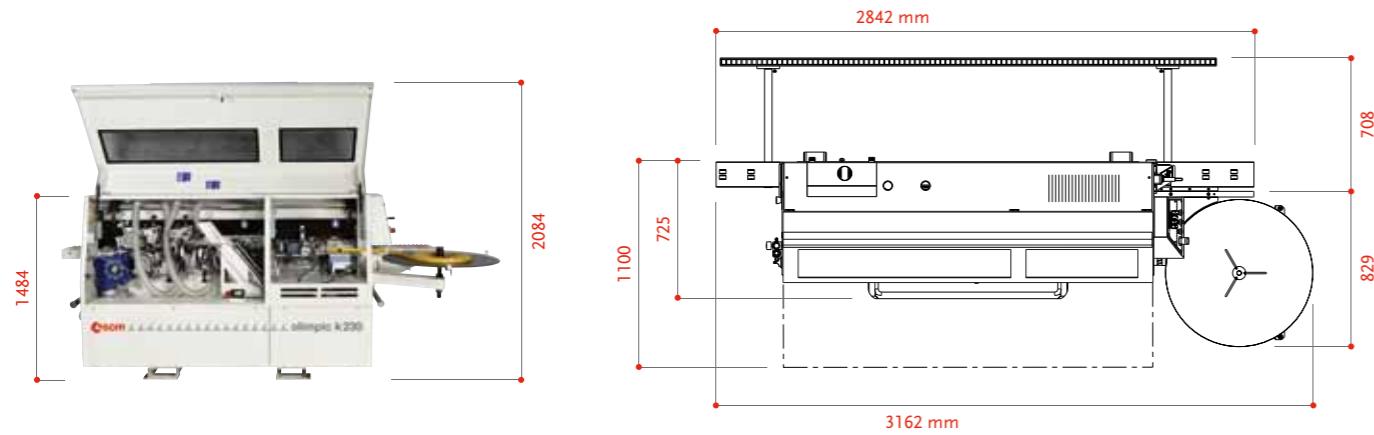

OLIMPIC K 230

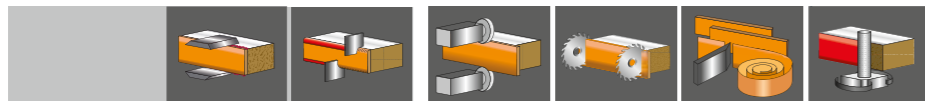

OLIMPIC K 230

noise level

Functioning conditions:		PANEL EDGE BANDING (reference standard EN 1218-4:2004+A2:2009)			
		Reference standard	Uncertainty factor K (68,27% probab)	Edge banding	
Lop: noise level at operator position - dB (A) and peak level [dB(C)]	Operator's position			VSA	LAV
	Input	UNI EN ISO 11201:97	≤ 2.5 [dB(A)]	74.8	75.4 [91.7]
	Output			75.5	77.8 [95.1]
Lw: emitted noise level dB(A)re 1pW [mW(A)]		ISO 3744-94	≤ 2 [dB(A)]	94.7 [2.9]	96.3 [4.3]

THE MAXIMUM INSTANTANEOUS C NOISE LEVEL IS UNDER 130DB (C)

VSA= No machining without dust extractor equipment LAV= machining

- scm**
- minimax**
- scm tecmatic**
- scm**
- routech**
- celaschi**
- dmc**
- superfici**
- sergiani**
- gabbiani**
- morbidelli**
- mahros**
- stefani**
- cpc**
- sag**
- scmgroup**
engineering
- delmac**
engineering
- scmfonderie**
- steelmec**
- hiteco**
- es**
- csr**
- CMS Cms**
wood technology
- CMS Cms**
advanced materials technology
- CMS Brembana**
stone technology
- CMS Brembana**
glass technology
- CMS CmsPlast**
plastic technology
- CMS Tecnocut**
waterjet technology
- CMS Balestrini**

1 large integrated group
 18 production sites
 29 specialist brands
 21 foreign branches
 more than 50 years in business
 70% exports
 350 agents and distributors
 365 registered patents
 500 engineers
 3.000 square metres of showroom
 10.000 classical and professional machines manufactured per year
 240.000 square metres of production space

passion**technology**performance

SINCERT



The technical data can vary according to the requested machine composition. In this catalogue, machines are shown with options. The company reserves the right to modify technical specifications without prior notice; the modifications do not influence the safety foreseen by the CE Norms



www.scmgroup.com/
qrcode/v1/



www.scmgroup.com/
it/mission_scm